



SERIES
FIVE



Solution Without Compromise



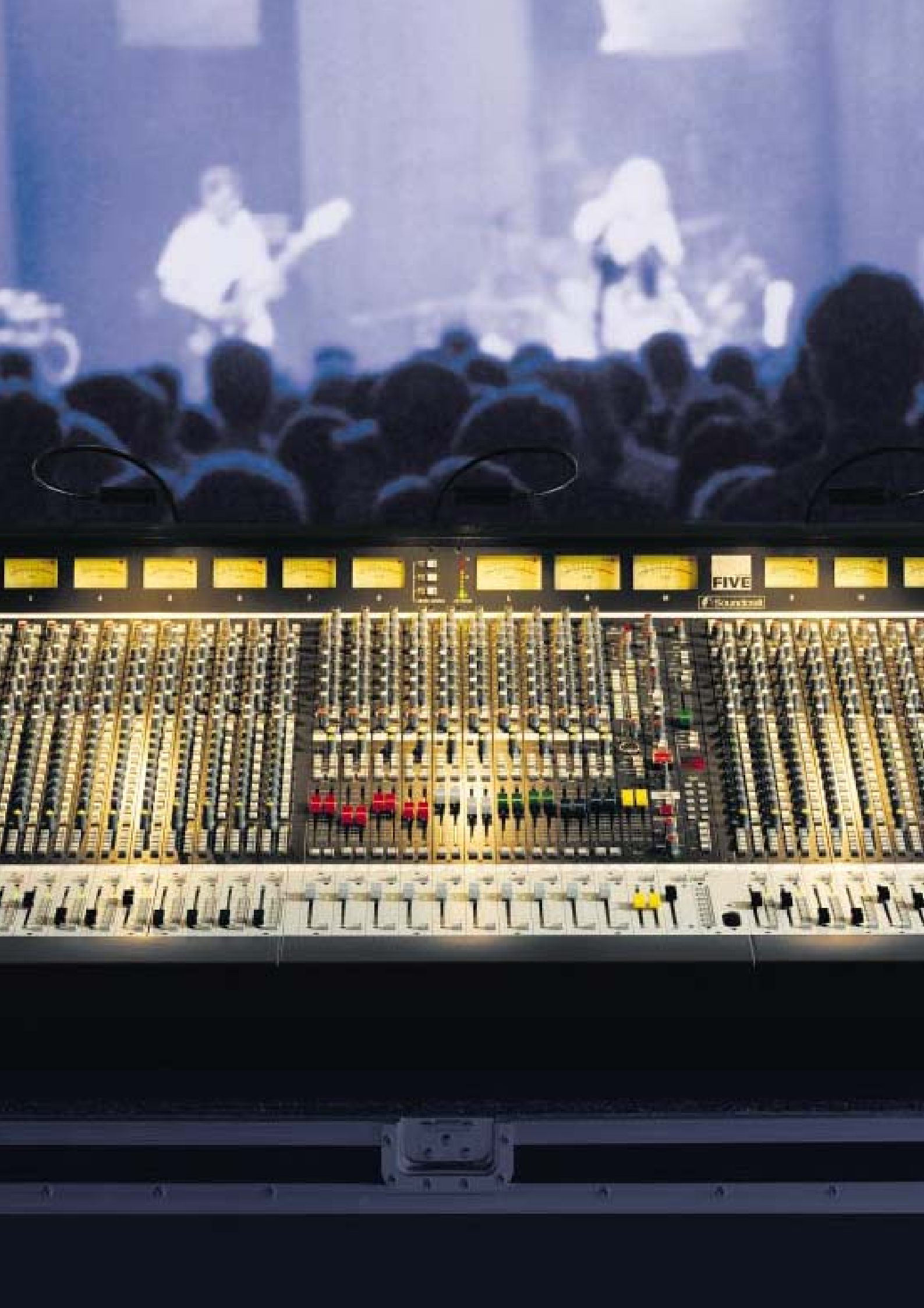

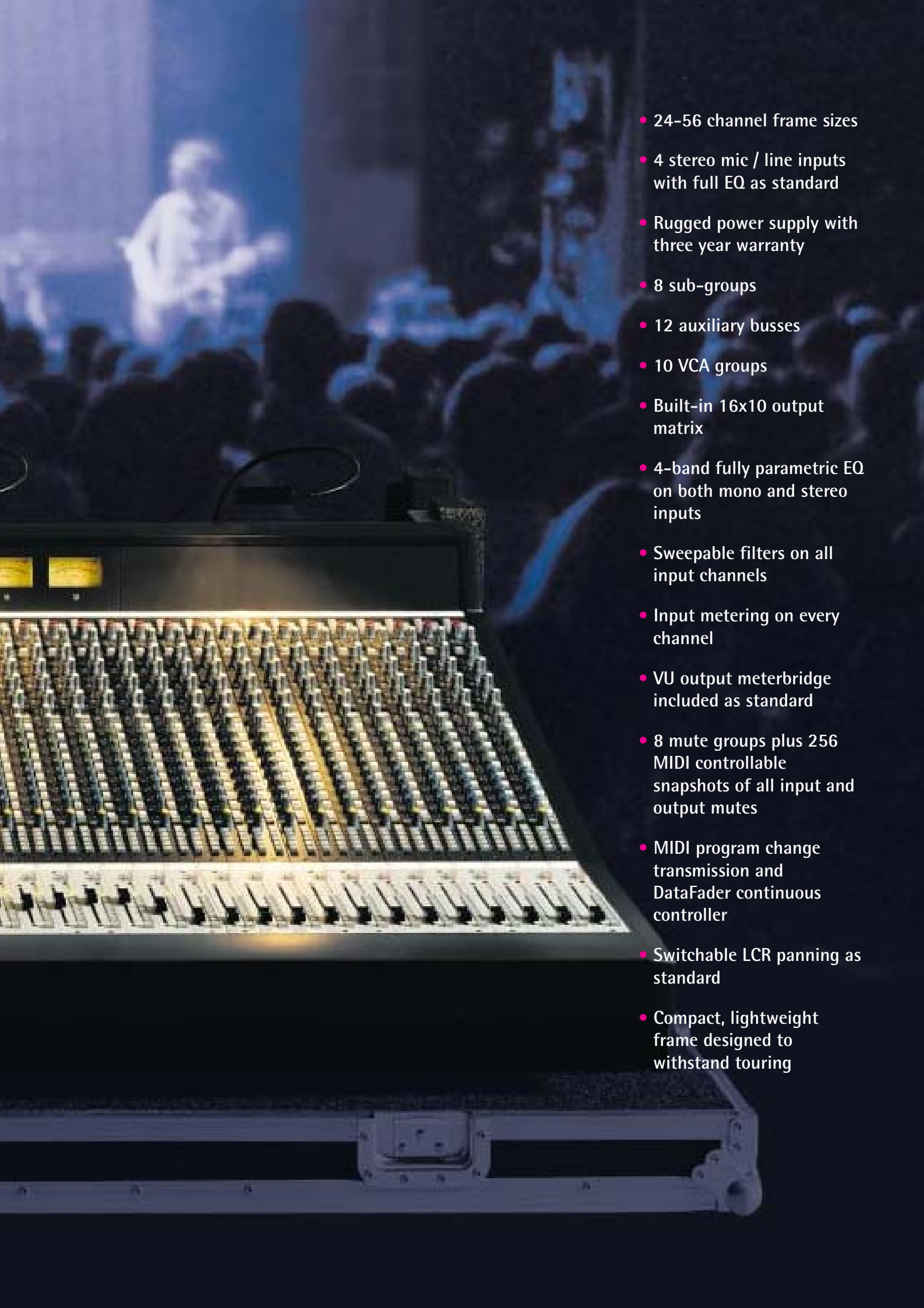

- 24-56 channel frame sizes
- 4 stereo mic / line inputs with full EQ as standard
- Rugged power supply with three year warranty
- 8 sub-groups
- 12 auxiliary busses
- 10 VCA groups
- Built-in 16x10 output matrix
- 4-band fully parametric EQ on both mono and stereo inputs
- Sweepable filters on all input channels
- Input metering on every channel
- VU output meterbridge included as standard
- 8 mute groups plus 256 MIDI controllable snapshots of all input and output mutes
- MIDI program change transmission and DataFader continuous controller
- Switchable LCR panning as standard
- Compact, lightweight frame designed to withstand touring

Soundcraft - Innovation In Live Sound

Over 20 years of success in mixing console design and manufacture has given Soundcraft unique insight into the demands of leading audio professionals. Through the application of this experience, and having sought the opinions of top live sound engineers and designers, Soundcraft has arrived at what it strongly believes to be its best front of house console yet. Soundcraft set out to provide a great-sounding, fully-featured and affordable live sound console. This is now complete, and is called Series FIVE.

Available in frame sizes of 24 to 56 input channels, Series FIVE is ideally suited to a whole range of demanding applications from touring to theatre installation. Series FIVE's comprehensive standard feature set includes LCR panning, aux master levels on 100mm faders, full-spec stereo modules and FX returns, plus flexible MIDI scene control. Despite the Series FIVE's high level of facilities, the console's layout is clear and reassuringly familiar. This has been achieved without compromising the audio quality.

A Proven History

Soundcraft has always been well respected for its audio performance and British sound, and this was never so true as with the Series Four and Europa consoles. Building on this success and combining it with the feature set and flexibility demanded by today's engineers, Soundcraft has created Series FIVE - the natural progression.



Designed For Professionals



WIDE RANGE OF FRAME SIZES

Five frame sizes are offered as standard - 24, 32, 40, 48 and 56 mono channels. Mono channels can be replaced by stereo modules, in blocks of two or four, together with the appropriate rear connectors.

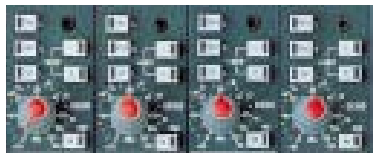

4 STEREO INPUTS INCLUDED AS STANDARD

Each frame size has an additional four stereo modules included as standard. These stereo mic / line channels are fully featured and include a four band fully-parametric EQ as per the mono input.



8 SUB-GROUPS

8 mono sub-groups are provided, each with an insert send and return on separate balanced jacks, plus routing via the pan pot to left / right / mono (centre).



12 AUXILIARY BUSES

All of the 12 auxiliary sends are independently on / off and pre / post switchable when the first four are globally set to act as two stereo sends. In this set-up the dual concentric pot controls level and

balance rather than individual levels. Aux 12 can be switched away from its bus to provide a channel direct output. These auxiliary outputs are routable to left / right / mono (centre) thus enabling them to be used as additional sub groups.

10 VCA GROUPS

A bank of 10 VCA groups is controlled by 100mm faders located below the output section. These determine the overall level and mute status of any input channel assigned to them.



SWEEPABLE FILTERS

Both the mono and stereo input channels include a sweepable high-pass filter while the mono module offers the additional flexibility of a sweepable low-pass filter.





BUILT-IN 16x10 MATRIX

In addition to the 8 sub-groups and 12 aux busses, Series FIVE offers a 16x10 output matrix. Each of the 10 outputs can be derived from the 8 sub-groups, left, right and mono (centre) outputs, aux busses 1-4 and an external stereo line input. Individual talkback and mute are provided, as well as external mute which is part of the console's snapshot automation system.

SWITCHABLE LCR PANNING

When activated via the switch on each mono channel, the LCR panning mode selects the mono bus as a dedicated centre output. The pan control then pans from left to centre, and centre to right.



When the pan pot is at its centre detent, audio output is removed from the left and right busses.

INPUT METERING ON EVERY CHANNEL

Signal level metering is built-in to every input channel. The mono module has a 10-segment LED bargraph situated adjacent to the fader for maximum visibility while the stereo channel uses five segments for each side of the stereo signal.

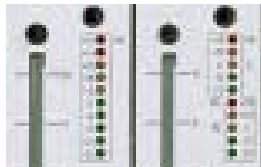

MUTE CONTROL / MIDI MUTE AUTOMATION

The Series FIVE MIDI module provides a comprehensive array of functions. 8 mute groups can be created, along with up to 256 snapshots of the console's mute switch status.



Each snapshot incorporates a MIDI Program Change message for automating setting changes in external effects units, plus a continuous controller number for the DataFader, delivering real-time control of external effects parameters.



Note On messages can also be transmitted to trigger samplers and other external units.

OUTPUT METERBRIDGE INCLUDED AS STANDARD

The Series FIVE meterbridge is fitted with 3 large VUs which read the master left, right and mono (centre) outputs, and 12 smaller VUs which are switchable between sub-groups 1-8, aux sends 1-12, and matrix outputs 1-



10 via the meter source switch bank. An LED phasemeter displays phase correlation between the left and right signals.



Creative Power



One of the most critical components in any console is its power supply and, with the CPS 2000 PSU, our designers and service engineers have created a device which sets new standards in performance and reliability. The use of high-quality components and fewer voltage rails makes for a simple, reliable system, and the CPS 2000 delivers ample headroom: a 48-channel Series FIVE enjoys 30% spare headroom capacity. A digital display on the front of the unit

provides precise continuous monitoring of incoming voltage, and with world-wide usage a prime consideration, Series FIVE will operate with inputs as low as 80 volts. Built-in diode linking allows two PSUs to function in parallel for

fail-safe operation, without the need for a switcher box, whilst heavy-duty Socapex® DC connectors link the PSU output to the console. The CPS 2000 is cooled by quiet yet hard wearing PAPST® fans, fitted with filters for easy access. CPS 2000 carries a three-year warranty.



- Linear circuitry uses industry standard components
- 30% spare headroom with standard 48-channel console
- Fewer voltage rails makes for a simpler, more reliable configuration
- Load is spread across several power devices on each rail for optimum heat dissipation
- Heavy current wiring is all hard soldered minimising number of connectors





Built To Last - But Designed To Be Moved

One of the priorities at the design phase of Series FIVE was to concentrate on creating a console which strikes the right balance between ruggedness and portability. The result is that a fully-specified 48-channel Series FIVE weighs just 180 kg/396 lbs, is under 227cm/90 inches wide and measures just 92cm/36 inches from front to back. It is a four-person lift, and smaller configurations can be lifted by just two crew. But its lightweight construction does not mean that Series FIVE has seen any compromise in its build quality. Its rugged sub frame has been designed to withstand the most demanding working environments. Series FIVE's compact size and comprehensive features, combined with its affordability, make it the perfect choice for tour sound companies, large installations, stadiums, and theatres alike. Series FIVE provides the solution without compromise.



- Front panel digital mains voltage meter aids correct voltage tap setting
- Built-in diode output linking allows two supplies to be connected for redundancy
- Heavy duty Socapex® DC connectors link PSU to console
- High quality PAPST® fans for reduced noise and longer product life
- 4U high 19" rackmountable



Rugged sub-frame construction



Series FIVE Input Modules

*Mono
input module*

Our research told us that live sound engineers want to see stereo modules as similar as possible to the mono, in terms of the features they offer. This is exactly what Series FIVE delivers. Many other consoles reduce the specification of their stereo modules, but with Series FIVE, the stereo input processing is almost as comprehensive as the excellent mono module. Stereo modules function equally well as input channels or as FX returns; and four are included as standard with every Series FIVE console in addition to the mono channels specified by the configuration.

INPUT STAGE

The mono module accepts two balanced inputs via XLRs at microphone or line level. The B switch selects the required signal, and individual +48V switches apply phantom power to either input. This flexibility means that a second console for the support band often becomes superfluous, as the engineer can use the B input for the support band multicore, and switch across to input A for the main act in seconds. The RNG button switches the range of the input stage between -2dBu to -70dBu and +10dBu to -20dBu, before the signal is routed through the SENS (Sensitivity) pot which then allows finer adjustment of input gain. This feature, unique to Soundcraft consoles, provides a much more efficient way to set signal levels in the input stage than a traditional PAD control. Amplifying a signal after it has been reduced in level by a PAD degrades the noise performance of the amplifier, as there is unnecessary gain present in the input stage. Also, the position of the resistors in a PAD circuit degrades the amplifier's common mode rejection (CMRR). In live applications which require long microphone cables and multicores, effective interference rejection is crucial. Series FIVE's input stage solves these problems by using two separate active gain

stages which are switched in and out as required via the RNG switch. The Phase (\emptyset) switch reverses the polarity of the selected input. The balanced insert point can be switched in circuit via the INS IN button.

The layout of the stereo module's input stage is as close as possible to that of the mono channel. Individual RNG and +48V buttons are provided for each side of the stereo input, while the Phase switch reverses the polarity of the left signal. The RNG and SENS functions work in exactly the same way as those on the mono module, meaning that the stereo channels will accept microphone levels, and are not line specific as on some consoles. Given that stereo modules can be specified instead of mono channels in banks of two or four, a 40-channel frame with 16 stereo inputs fitted will yield a massive 60 microphone-capable inputs in an extremely compact size.

FILTERS

A smooth, accurate filter system is crucial to live sound engineering. Both modules boast a sweepable high-pass filter which can be switched out of the chain when not in use, and the mono channel has the additional flexibility of a switchable low-pass filter.

EQ

Soundcraft consoles are renowned for their smooth, musical EQ and Series FIVE is no exception. The legendary four band, fully parametric EQ seen on the Series Four and Europa consoles has been further refined for Series FIVE, and is fully implemented on both mono and stereo modules. The one slight difference is that to use the HF and LF bands as shelving EQ, there are switches on the stereo module, whereas on the mono channel a click switch at the end-stop of the Q pot invokes this function. On both modules, the EQ can be switched completely out of the signal chain when it is not in use.

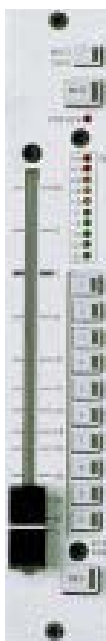

Stereo
input module



AUXILIARY SENDS

12 full-time auxiliary sends are provided, which when combined with the 8 sub-groups and 10 matrix outputs, make ample provision for effects sends, foldback mixes, additional feeds and other output requirements. Sends 1-4 can be globally switched in pairs (the button is located on the output section) to act as stereo sends, in which case the dual concentric controls act as level and balance, rather than as individual level controls. On the stereo module, switches on Aux 1-4, 5/6 and 7/8 allow the engineer to select whether these sends are derived from a summed mono signal, or sourced as stereo from the left and right sides of the stereo channel. On the mono module, Aux 12 can be routed away from its bus and to the direct output via the DIR switch; this allows the engineer to create a pre-fader direct output, ideal when making a simultaneous multitrack recording.

ROUTING AND PANNING

Individual routing switches send the post fade signal to the 8 sub-groups (direct or through the pan pot depending on the setting of the PAN switch), the mono bus (MNO), or the main left-right outputs (MIX). The LCR button on the mono module uses the mono bus to provide a dedicated centre output. On the stereo module, the pan pot is dual concentric, providing full independent left-right panning of each side of the stereo signal, or easy control over the width of the stereo image.

FADER AND MUTING

A high quality 100mm fader controls the output level to all busses, and offers 10dB of gain when fully raised. An expanded scale is provided around unity for precise control. The channel Mute switch can be

remotely controlled from the mute master section, and the semi-recessed Mute Safe switch protects the channel from mute groups, VCA mutes, snapshots, or Solo-in-place - the channel can still be muted locally. The Preview LED allows editing and checking of mute groups and snapshots without disturbing the audio passing through the channel. The 10 numbered switches assign the channel to any combination of the 10 VCA groups, which then assumes control of the level, mute and solo buttons on that channel. The Solo button provides either a mono PFL or a stereo AFL, or Solo-in-place, depending on the mode selected on the master section.

INPUT MODULES BACK PANEL CONNECTIONS

Mono Module

Inputs A and B are connected via the balanced XLR sockets. The direct output is on a balanced XLR, and the insert sends and returns are all on separate balanced 1/4" jacks.

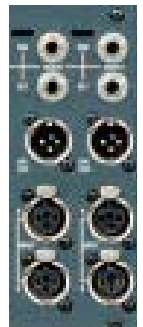

Stereo Module

The inputs are on two balanced XLRs, and individual insert sends and returns for each side of the stereo signal are provided on balanced 1/4" jacks.

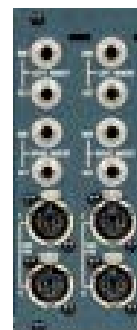

Series FIVE Output Section

*Sub-group
output module*

The output section of Series FIVE revolves around the principle that output controls for both auxiliary masters and sub-group sends should be identical, so that they are interchangeable according to the current task. Therefore if the 8 sub-groups are not enough for a particular job, some of the 12 auxiliary sends can be used as additional groups. The output section consists of 10 identical dual modules - 4 of which control the 8 sub-groups, with the other 6 controlling the 12 auxiliary sends. Each module also controls one of the 10 matrix outputs.

MATRIX OUTPUTS 1-10

A 16x10 output matrix is provided as standard on the output section of every Series FIVE console, and combines with the sub-groups and aux sends to provide an outstanding level of mixing versatility. Each output can be derived from any combination of sub-groups 1-8, aux sends 1-4, the main left-right busses, the mono output, and a dedicated external stereo input. The left side of the external input is normally fed to the odd-numbered matrices, and the right side to the even, although jumper options allow the signal to be summed. Contributions from the 8 subgroups, left-right, mono + aux 1/2 and 3/4 make up the matrix mix, and are individually controllable via rotary pots. A balanced insert is switchable via the IN button, and the

latching TB button injects the talkback or oscillator signal (as determined in the master section) into the matrix output, pre-fader. The rotary Matrix Master fader has AFL or PFL solo (depending on settings in the master section) as well as a Mute switch which can be activated by the 8 mute groups or the 256 snapshot settings. A Mute Safe switch protects the output from remote muting, while retaining the capacity for local muting.

8 SUB-GROUP MASTER FADERS

Each sub-group has a high quality 100mm fader (coloured red) controlling the level to the balanced output. A balanced insert point is provided, which is switchable via the IN switch. Mute and Mute Safe buttons function in the same way as those on the matrix outputs, and the Solo buttons provide AFL or PFL facilities depending on the settings in the master section. The sub-groups can be routed to the mono and / or left-right busses via the To Mono and To Stereo buttons; a pan pot is provided for sweeping between the left-right busses.

12 AUXILIARY MASTER FADERS

Each auxiliary master is controlled by a high quality 100mm fader (coloured to match the send knobs on the inputs). Features of the auxiliary master output section are identical to those of the sub-group section, allowing any spare auxiliaries to be used as sub-groups if required.

*Master / group upper
rear connector panel*

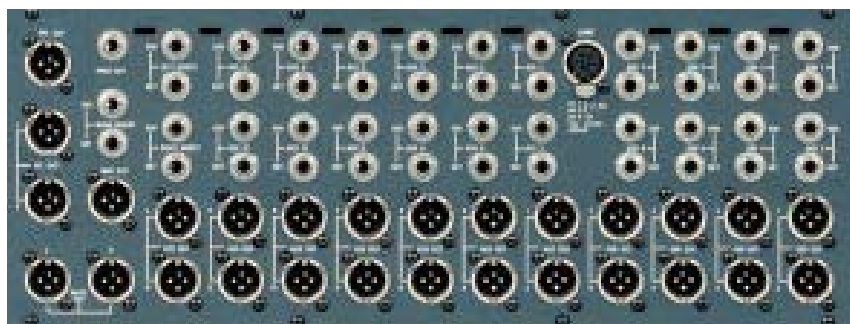

*Auxiliary
output module*



GLOBAL MONO / STEREO SWITCHING

Auxiliaries 1-4 can be used as four individual mono sends, or they can be ganged and used as two stereo sends. In the first instance, the dual concentric send controls on the input modules control individual levels, and in the second they control level and balance. The first two auxiliary master modules feature switches for setting this mode, which can be set independently for Aux 1/2 and Aux 3/4. In addition, in stereo mode, the Mute and Solo buttons on the output modules are logic linked such that the operation of one will automatically trigger the other.

METERING

Every Series FIVE console features an integral VU meterbridge. 3 large VUs are dedicated to measuring the left, right and mono (centre) outputs. A bank of 12 smaller VUs can be selected to read sub-groups 1-8, aux sends 1-12 or matrix outputs 1-10 via a meter source switch bank. The left and right meters also automatically switch to read any soloed signal. A unique feature of Series FIVE is

the integral LED phasemeter, which measures the phase correlation of any signals which appear at the L and R VU meters. This will normally be the left and right outputs, but when in stereo AFL mode, the phase of any soloed stereo source can be checked.

MASTER / GROUP UPPER BACK PANEL CONNECTIONS

The 8 sub-groups, 12 auxiliaries, left, right and mono outputs are all on balanced XLRs, with inserts on balanced 1/4" jacks (individual for send and return). Other balanced XLR outputs are for monitor output, PFL and stereo AFL. A headphones socket is provided which mirrors the one on the front panel of the master section. A 4-pin XLR socket offers 400mA of power for the connection of Littlites™ - the number of these outlets varies according to console frame size.

10 VCA GROUPS

A bank of 10 VCA master faders controls the level of any mono or stereo channel assigned to a VCA group. Mute and Solo buttons are provided for each fader, and act effectively as a remote control for any channel assigned to that VCA group (unless that channel has its Mute Safe function engaged). Therefore any solo mode (PFL, stereo AFL or Solo-in-place) can be activated for an entire VCA group, depending on the setting of the global console solo mode. The Nominal LED on each fader allows fast and accurate return to unity gain.

*VCA
control
faders*

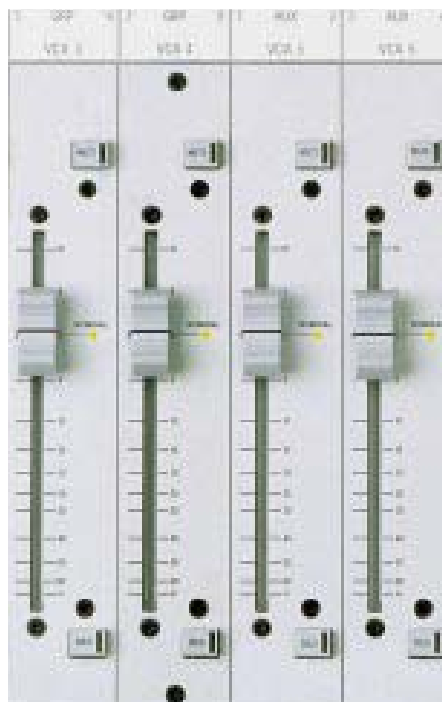

Series FIVE Master Section



Master 1
module

The Series FIVE master section is two modules wide and contains the main left, right and mono faders, as well as monitoring controls, talkback, and an array of controls which further enhance the flexibility of Series FIVE.

PSU RAILS

Voltage indicators for the +/-17V, +5V and +48V rails on the PSU are provided and offer constant visual confirmation that the power supply is providing an accurate voltage.

TALKBACK AND OSCILLATOR

The built-in oscillator can generate pink noise or a sine wave in a frequency range of 63Hz to 10kHz. The PINK button toggles between pink noise and sine wave, and the x10 button increases the range of the oscillator frequency control from 63Hz-1kHz to 630Hz-10kHz. An oscillator level pot is also provided. The oscillator can be routed to its dedicated output (on balanced XLR) or to a combination of sub-groups, aux busses, left, right and mono outputs. The busses which receive the oscillator signal are determined by a bank of illuminated switches, which also nominates the busses which will receive the talkback signal when the INT button is depressed. This facility is also provided on the matrix outputs, by using the TB switch on each matrix master. Talkback can also be routed to its Soundcraft proprietary intercom output (compatible with SM monitor consoles or another Series FIVE)

via the EXT button. An external talkback input is provided for accepting such a link with another Series FIVE. A front panel talkback mic input socket (XLR) is provided, together with a level control, a -30dB pad switch and a +48V phantom power button, and for convenience this socket is mirrored on the back panel.

ALTERNATE STEREO OUTPUTS

In addition to the main left-right stereo mix outputs, three alternate stereo outputs are provided, which allow the creation of feeds for broadcast or recording which would otherwise tie up several matrix outputs. ALT STE1 is controlled by two 100mm faders, and the levels of ALT STE2 and ALT STE3 are on rotary faders. All are switchable to be pre or post the main left-right faders, and all have a MNO button which sums the two sides of the stereo signal, thereby offering a mono feed.

AUX RETURNS

Two auxiliary returns are provided, with sensitivity switchable between -10dBV and +4dBu, and with the signal routed directly into the left-right mix bus. 2-band shelving EQ at 60Hz and 12kHz is provided, and the input level is controlled by a rotary fader. Mute and Mute Safe are provided, and the Solo button will allow mono PFL or stereo AFL monitoring, depending on the setting of the console's global solo mode.

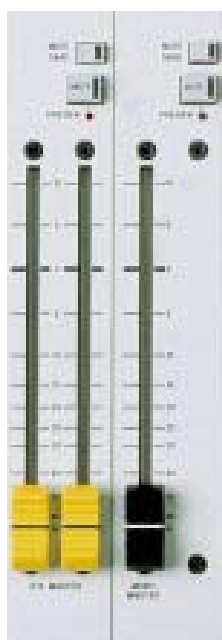

Master / group lower
rear connector panel

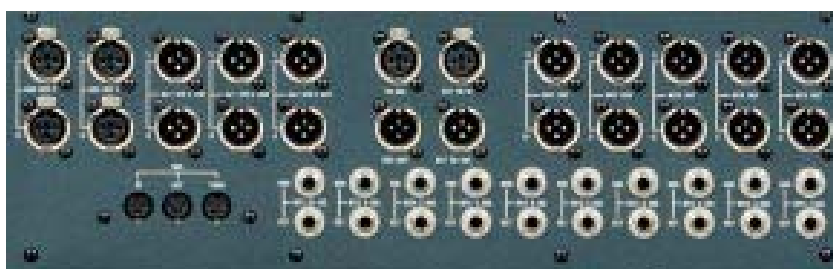

Master 2 module



SOLO CONTROLS

Every aspect of Series FIVE's design has been carefully thought out, and the solo system is certainly no exception. It has been carefully developed in conjunction with mixing professionals, to ensure that this crucial aspect of the console's design is flawlessly implemented. The Master Mode button dictates whether the selection of a Solo function should result in mono PFL or stereo AFL monitoring, unless the large protected Solo-in-place button is lit. In this instance the destructive in-place stereo solo will be engaged, allowing the engineer to listen to a channel in its proper place in the stereo field, plus any associated effects. Rotary pots are provided to trim the level of the AFL and PFL busses. The Auto Cancel facility means that any Solo button selected will cancel the previous solo. When not in this mode, the selected Solos become additive. With the Input Priority button on, soloing an input channel will temporarily override any output solo which may be present. When the input solo setting is released, the original output solo will again become active. A large illuminated Solo Clear button allows fast, one touch cancelling of all solo settings throughout the entire console control surface.

MONITOR CONTROLS

Separate rotary fader controls are provided for headphone level and monitoring level. The two outputs follow the same source; this is selected between the mono bus and the main left-right mix

outputs. The stereo signal can be summed if required via the SUM L+R button. The selected monitor source will be overridden by any input or output solo operation.

MASTER FADERS

Levels for the mono and left-right mix outputs are controlled by 100mm long throw faders. The stereo faders are yellow and the mono fader is black. Mute and Mute Safe switches are provided for each. The mutes can be controlled by the snapshot system.

MASTER / GROUP LOWER BACK PANEL CONNECTIONS

The outputs for the 10 matrix sends are on balanced XLRs, and each has an insert with send and return on separate balanced 1/4" jacks. The two stereo aux returns are on balanced XLRs, as are the three alternate stereo outputs. Standard MIDI in, out and thru ports are provided. An oscillator output, external talkback output, external talkback input and talkback mic input are all connected via balanced XLRs.

LINK BACK PANEL CONNECTIONS

Sub-groups 1-8, auxiliaries 1-12, PFL, AFL, mono and left-right mix busses are all available for audio linking in situations where two Series FIVE consoles are being linked. Inputs flow straight into the busses at unity gain, and all bus inputs are accessed via balanced XLRs. 38-way EDAC logic in and out connectors allow full logic linking of VCAs and solo controls between two Series FIVE consoles.

Link rear connector panel

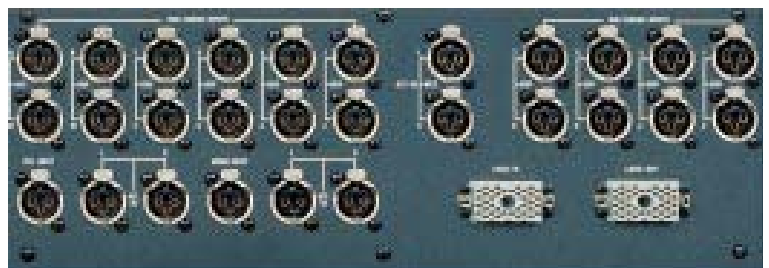

Mute Control / MIDI Module



MIDI / mute module



MUTE CONTROL / MIDI MODULE

Series FIVE's mute control and MIDI section allows the creation of 8 mute groups and up to 256 snapshots of the console's mute switch status, as well as the transmission and reception of MIDI program change and note ON/OFF messages, allowing the console to exercise real-time control over any suitably specified MIDI device.

PREFERENCE SETTINGS

Under normal circumstances, when a Solo-in-place or a VCA mute is activated, all affected channel mute buttons will flash to indicate that they are being muted by remote control. This flashing effect can be disabled if desired using the recessed button. A rotary pot controls the brightness of the Littlites™ connected to the power outlet ports on the rear panel. In the unlikely event of system failure, the backup contingency of a Processor Reset button allows complete disabling of the mute control processor, allowing all console mutes to operate manually.

BULK DUMP BUTTONS

The memory contents of Series FIVE can be saved to and reloaded from an external MIDI device such as a sequencer or data filer. This means that snapshot set-ups can be archived and recalled at a moment's notice.

DATAFADER

The DataFader that proved so successful on previous Soundcraft consoles has been even further improved and comprehensively implemented on Series FIVE. The fader

sends out continuous controller data to the MIDI OUT socket whenever it is moved on its currently assigned MIDI channel. The ON button allows the fader to be disabled, or to be punched in at a set value. The fader position is storable in a snapshot, for automation reset.

MUTE ACTIVE AND PREVIEW

In active mode, any snapshot or mute group which is recalled will instantly override any mutes which are currently set. In Preview mode, recalling a snapshot or mute group will not change any settings, but will make the preview LEDs beside the relevant Mute buttons flash. This allows the engineer to check a mute group or snapshot during a show without affecting the audio. Snapshots and mute groups can also be edited and stored in this mode, again with no audible effect.

NUMERICAL KEYPAD

The 0-9 numerical keypad and its adjacent up / down buttons allow direct or incremental keying of snapshot or program change numbers into the digital display.

MUTE MASTER BUTTONS

The large illuminated mute master buttons allow fast store and recall of the 8 mute groups. More than one mute group can be active at once, thereby layering the groups. This section also houses the angled recessed headphones socket.

Series FIVE Jumper Options

Module	Function	Options	Default
Mono	Channel insert	Pre or post EQ	Pre EQ
Mono	I/P channel meter source	Pre or post fade	Pre fade
Mono	Aux 1-4 PRE source	Pre or post EQ (always pre fader)	Post EQ
Mono	Aux 5-8 PRE source	Pre or post EQ (always pre fader)	Post EQ
Mono	Aux 9-11 PRE source	Pre or post EQ (always pre fader)	Post EQ
Mono	Aux 12 PRE source / DIR	Pre or post EQ (always pre fader)	Post EQ
Mono	Pre EQ feed	Pre or post mute	Post mute
Stereo	Channel insert	Pre or post EQ	Pre EQ
Stereo	I/P channel meter source	Pre or post fade	Pre fade
Stereo	Aux 1-12 PRE source	Pre or post EQ	Post EQ
Stereo	Aux 9, 10 source	Mono or stereo	Mono
Stereo	Aux 11, 12 source	Mono or stereo	Mono
Stereo	Pre EQ feed	Pre or post mute	Post mute
Output	Matrix ext I/P sensitivity	-10dBV or +4dBu	+4dBu
Output	Matrix ext I/P source	Ext I/P left, right or mono	Left to odd, right to even

Series FIVE MIDI Applications

The mixing engineer today is required to deal not only with the audio mixer itself, but also with a bank of external programmable effects units, samplers and other replay devices. Series FIVE integrates a high level of MIDI control into the front panel of the console, which allows the engineer to automate much of the outboard equipment switching and parameter changing.

Series FIVE MIDI For System Setup

Many outboard processing devices have memories or patch locations into which the user can store settings for different sections of the show. Recalling these settings manually from the front panel of the unit entails leaving the mixing surface, thereby distracting the attention of the engineer. Series FIVE can send a user-

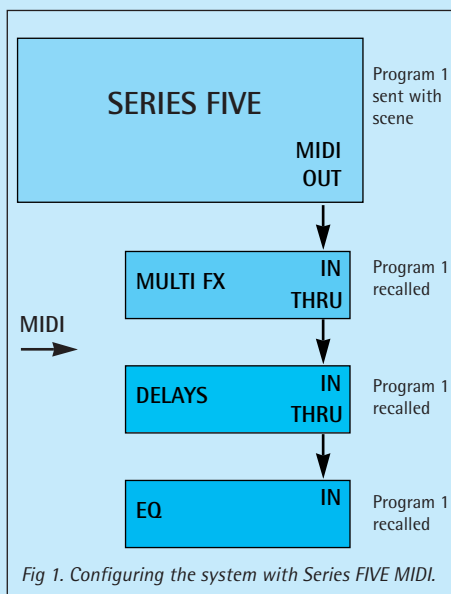

Fig 1. Configuring the system with Series FIVE MIDI.

programmable MIDI program change message for each snapshot to the MIDI OUT port at the rear of the console. This can be connected to the MIDI IN on any suitably-equipped device, which will then receive that Program change. This is interpreted by the effects unit and is equivalent to recalling a new memory location from the front panel of the device itself. For example, Program Change no 1 sent on MIDI Channel 1 will change the device receiving on MIDI Channel 1 to the first memory location, Program Change no 2 will select the second, and so on.

Although Series FIVE generates just one Program Change per snapshot, if all remote devices are set up to receive on the same MIDI channel, then they will ALL follow the Program Changes sent from Series FIVE, as shown in figure 1. In this example, the MIDI OUT of the console is connected to a multi-effects unit, a delay device, and a programmable EQ. All units have the correct settings for the beginning of the

event stored in memory location 1. Series FIVE sends Program Change no 1 on MIDI Channel 1 to the first effects device. This Program Change is then passed THRU to the remaining devices. Whatever the status of these devices, they are instantly reset to Memory location 1, ready for the start of the show, without the user having to touch any of the units.

Series FIVE MIDI For Sample Triggering

MIDI will also handle NOTE ON and NOTE OFF messages, which are equivalent to playing notes on a sampler keyboard, with 128 note values covering the keyboard range. These message

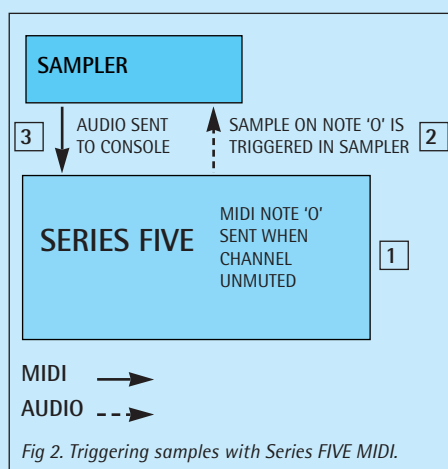

Fig 2. Triggering samples with Series FIVE MIDI.

types are particularly useful in live sound, since they allow sound effects to be recorded directly into a sampler, and played back manually via MIDI at the FOH position.

Series FIVE is capable of generating MIDI NOTE ON/OFF information whenever a MUTE is toggled. This allows a MIDI sequencer to be used to record a precise sequence of MUTE switching for playback at a later stage. In addition, since this information is generated such that NOTE ON is transmitted for MUTE OFF, the function can be used to trigger external devices such as samplers when the associated console channel is opened. Since each of the desk channels sends a unique note number, triggering a sample simply involves positioning that sample to respond at the correct pitch on the corresponding note number in the sampler. Sample HOLD should be set to ON, so that the entire sample is played even though the note on message is momentary. The sample should be assigned to an individual output on the rear of the sampler, which should be connected to the appropriate input channel on the console, as shown in figure 2. When that channel is un-muted, the MIDI NOTE ON will trigger the sample, which will pass through the newly un-muted audio path.

The DataFader

The DataFader is a continuous controller which provides direct real-time access to chosen parameters in an external MIDI unit. For example, in a situation where an actor moves from a spoken passage into a song and the required effect changes from a small reverb to a tapped delay, the transition must be smooth, as the scenes flow into one another.

First, the effects unit needs to be programmed with a patch which includes both reverb and tapped delay, but initially is mixed 100% to the reverb component. To mix between the two, controller number 3 can be used, as this is undefined and therefore should not clash with another parameter. The FX unit should then be set up to map controller number 3 onto EFFECT MIX (between reverb and delay), with value 0 being 100% reverb, and value 127 being 100% delay. The DataFader should be configured to transmit CC 3, and MIDI channels and program change information matched with the target unit. When that scene is recalled, the program change will set up the special patch. The fader can now be brought down to the bottom of its travel, and switched ON. When the fader is moved up, the CC information will update the MIX parameter in the FX unit, thus crossfading from the reverb into the delay.

Other Uses Of The Scene Memories

In ordinary usage, each scene memory might simply correspond to a scene, or song on the stage. However, MUTE status need not change from one cue to the next, so if several program changes had to be fired out in quick succession, the mutes in three or four consecutive memories could be stored identically, but the memories could carry different program changes - the desk will remain in the same mute configuration, but FX / outboard settings will change. This also applies to the DataFader - to gain access to several parameters during a scene, simply assign as many consecutive cues as required to contain the same program change and mute information, but with different CC numbers. Alternating between the appropriate memories as required will give control over a different parameter in each memory.

System Block Diagram

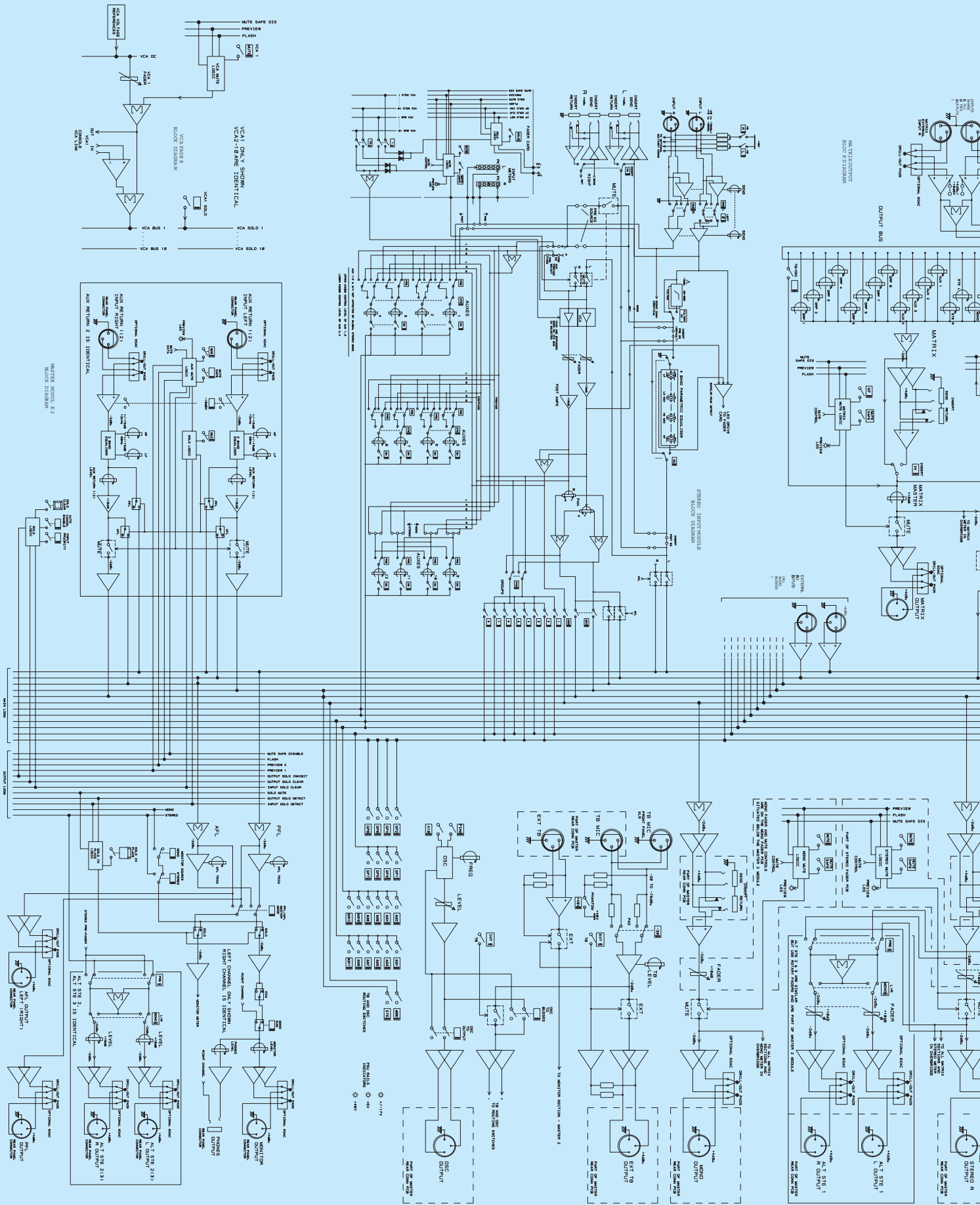

Level Diagram

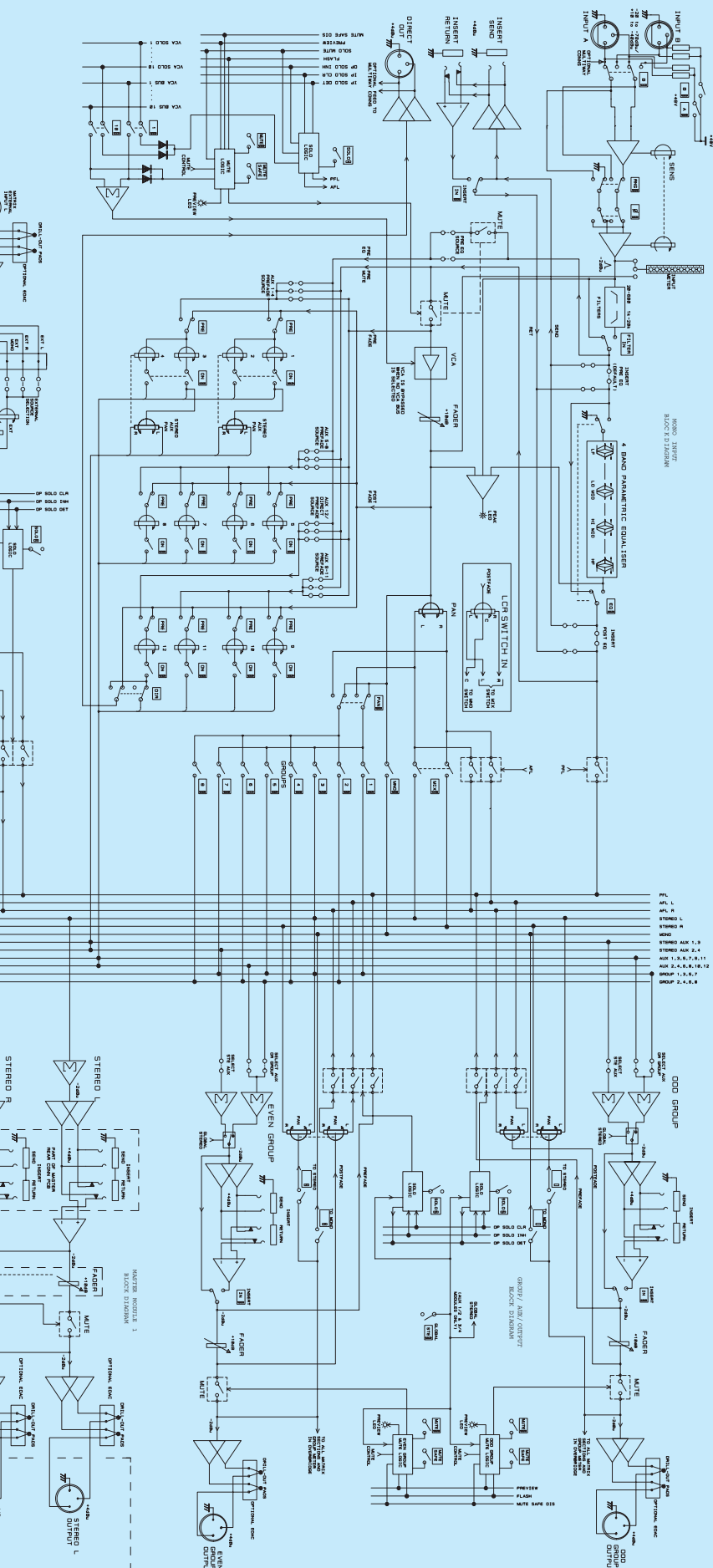
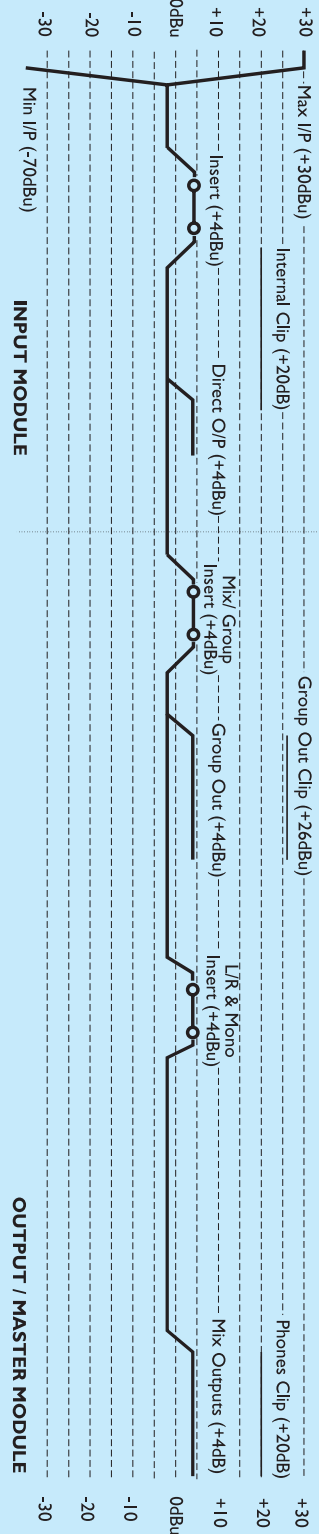

Dimensions

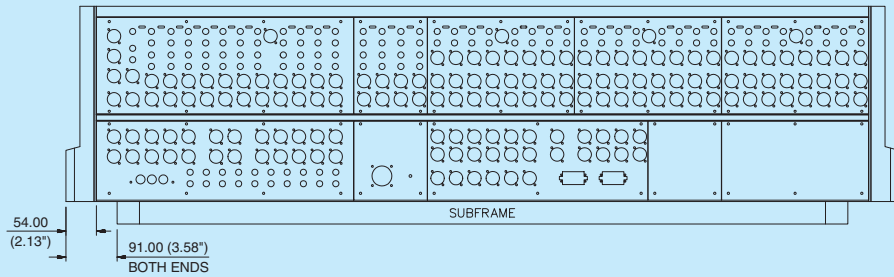
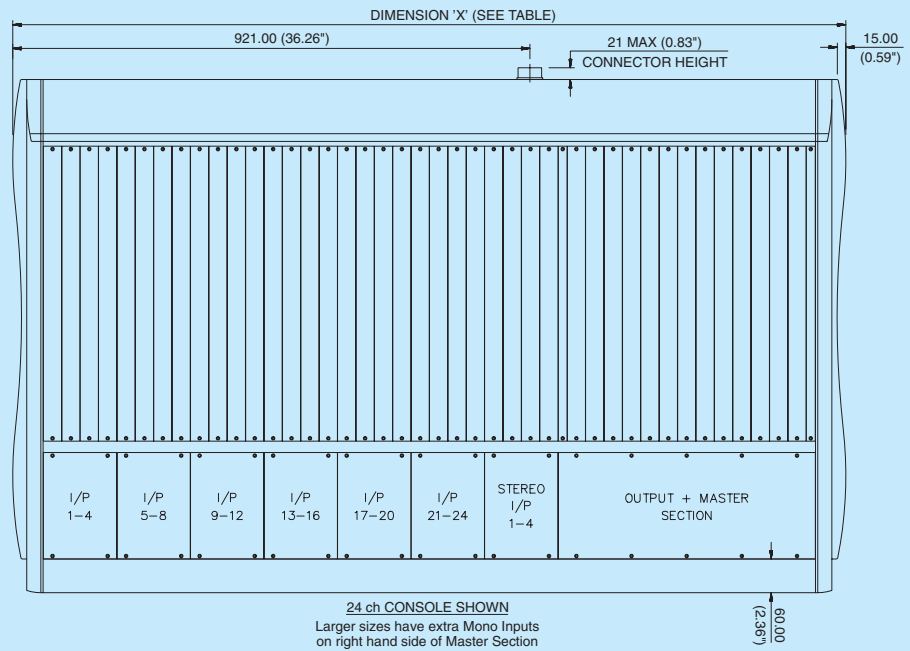
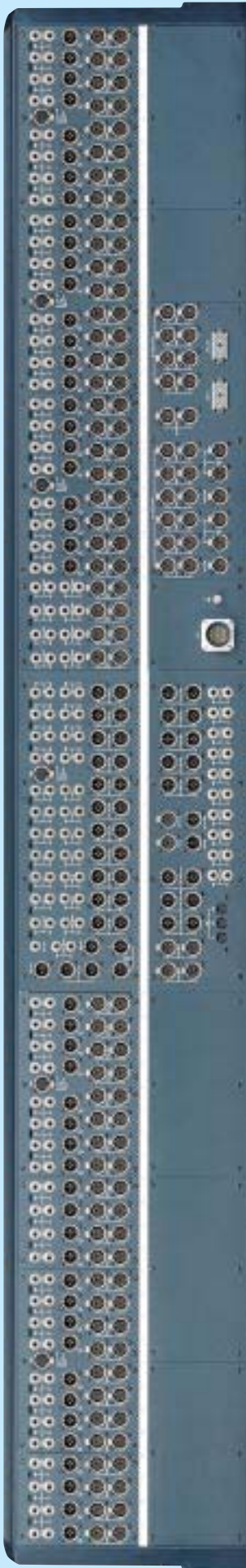

Console	Dimension 'x'
24Ch	1483.80 (58.42")
32Ch	1745.80 (68.73")
40Ch	2007.80 (79.05")
48Ch	2269.80 (89.36")
56Ch	2531.80 (99.67")

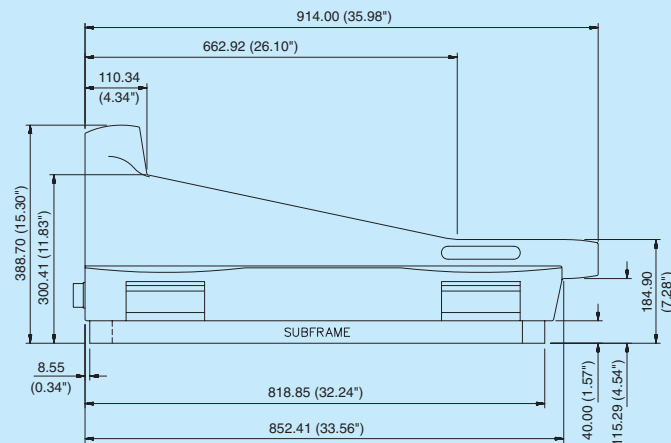

Input / Output Specifications

	Module	Signal	Conn.	Pin	Nom Level	Max Level	Impedance
Inputs	Mono Input	Input (A & B)	Female XLR	Pin 1 - Ground Pin 2 - Signal Hot Pin 3 - Signal Cold	-70 to -2dBu -20 to +10dBu (Switched Range)	+30dBu	2kΩ
	Stereo Input	STE IN (Left & Right)	Female XLR	Pin 1 - Ground Pin 2 - Signal Hot Pin 3 - Signal Cold	-70 to -2dBu -20 to +10dBu (Switched Range)	+30dBu	2kΩ
	Matrix	Ext. In (Left & Right)	Female XLR	Pin 1 - Ground Pin 2 - Signal Hot Pin 3 - Signal Cold	+4dBu	+26dBu	> 10kΩ
	Master	TB Mic I/P	Female XLR	Pin 1 - Ground Pin 2 - Signal Hot Pin 3 - Signal Cold	-20 to -70dBu	0dBu	2kΩ
		EXT TB I/P	Female XLR	Pin 1 - Ground Pin 2 - Signal Hot Pin 3 - Signal Cold	+4dBu	+26dBu	> 10kΩ
		Aux Returns (L & R for 1 & 2)	Female XLR	Pin 1 - Ground Pin 2 - Signal Hot Pin 3 - Signal Cold	+4dBu/ -10dBV	+26dBu/ +12dBV	> 10kΩ
Insert points	Mono Input	Channel Snd & Ret	TRS (1/4" Jack)	Tip - Signal Hot Ring - Signal Cold Sleeve - Ground	Send +4dBu Return +4dBu	+26dBu (into 1kΩ) +21dBu	Send < 75Ω Return > 15kΩ
	Matrix	Matrix Snd & Ret	TRS (1/4" Jack)		Send +4dBu Return +4dBu	+26dBu +21dBu	Send < 75Ω Return > 15kΩ
	Group/Aux Master	Group/Aux Snd & Ret	TRS (1/4" Jack)		Send +4dBu Return +4dBu	+26dBu (into 1kΩ) +21dBu	Send < 75Ω Return > 15kΩ
	Output Master	Main Mono, L & R Snd & Ret	TRS (1/4" Jack)		Send +4dBu Return +4dBu	+26dBu (into 1kΩ) +21dBu	Send < 75Ω Return > 15kΩ
Outputs	Mono Output	Direct Output	Male XLR	Pin 1 - Ground Pin 2 - Signal Hot Pin 3 - Signal Cold	+4dBu	+26dBu (into 1kΩ)	< 75Ω
	Matrix	Matrix Output	Male XLR	Pin 1 - Ground Pin 2 - Signal Hot Pin 3 - Signal Cold	+4dBu	+26dBu (into 1kΩ)	< 75Ω
	Group Master	Group Output	Male XLR	Pin 1 - Ground Pin 2 - Signal Hot Pin 3 - Signal Cold	+4dBu	+26dBu (into 1kΩ)	< 75Ω
	Aux Master	Aux Output	Male XLR	Pin 1 - Ground Pin 2 - Signal Hot Pin 3 - Signal Cold	+4dBu	+26dBu (into 1kΩ)	< 75Ω
	Output Master	L/R/Mono/Alt 2&3 L&R Outputs	Male XLR	Pin 1 - Ground Pin 2 - Signal Hot Pin 3 - Signal Cold	+4dBu	+26dBu (into 1kΩ)	< 75Ω
		Ext TB Output	Male XLR	Pin 1 - Ground Pin 2 - Signal Hot Pin 3 - Signal Cold	+4dBu	+26dBu (into 1kΩ)	< 75Ω
		Oscillator Output	Male XLR	Pin 1 - Ground Pin 2 - Signal Hot Pin 3 - Signal Cold	+4dBu	+14dBu (into 1kΩ)	< 75Ω
Headphones Output		TRS (1/4" Jack)	Tip - Left Ring - Right Sleeve - Ground	+4dBu	+20dBu (into 600Ω) 0dBu (into 8Ω)	50Ω	
Console Linking Inputs	All Inputs	Female XLR	Pin 1 - Ground Pin 2 - Signal Hot Pin 3 - Signal Cold	+4dBu	+26dBu	> 15kΩ	

EQ Curves

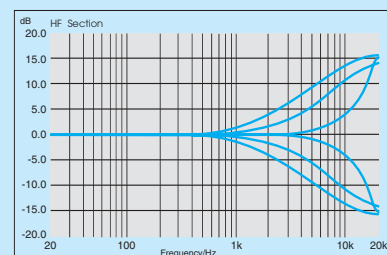
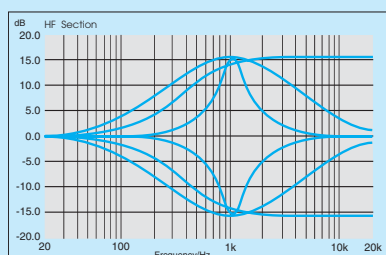
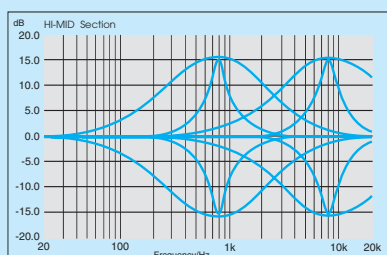
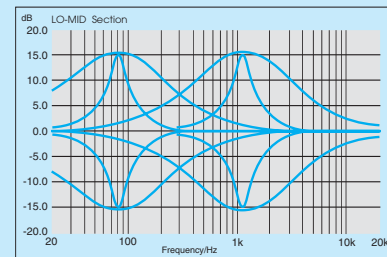
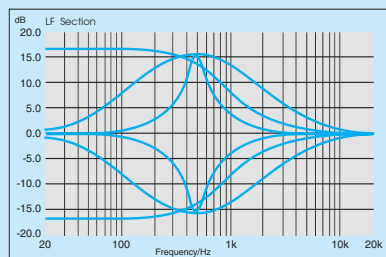
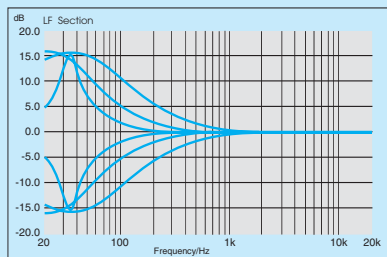

Series FIVE Typical Specifications

Frequency Response	XLR input to any output: +0/-0.5dB, 20Hz - 20kHz	
T.H.D. and Noise (All measurements at +20dBu)	XLR In to Direct Out (VCA Out)	<0.004% @ 1kHz <0.02% @ 10kHz
	XLR In to Direct Out (VCA In)	<0.015% @ 1kHz <0.04% @ 10kHz
	XLR In to Mix Out (VCA Out)	<0.005% @ 1kHz <0.02% @ 10kHz
Mic Input E.I.N.	22Hz - 22kHz bandwidth, unweighted: ... < -127.5dBu (200Ω source)	
Residual Noise	Mix Output, no inputs routed, Mix fader @ 0dB: -90dBu	
Bus Noise	Mix Output: 32ch routed, faders @ -∞, Mix fader 0dB: < -78dBu Grp Output: 32ch routed, faders @ -∞, Grp fader 0dB: < -78dBu	
Crosstalk (1kHz, +20dBu input signals)	Input Channel muting:	> 100dB
	Input fader cutoff:	> 90dB
	Input pan pot isolation:	> 85dB
	Input A to B isolation:	> 80dB
	Stereo L/R isolation:	> 80dB
	Mix routing isolation:	> 100dB
	Group routing isolation:	> 100dB
	Group-group crosstalk:	> -90dB
	Group-Mix crosstalk:	> -90dB
Mix-group crosstalk:	> -90dB	
CMRR	Mono Input, A or B Inputs - 60dB @ 1kHz	
Oscillator	63Hz to 10kHz / pink noise, variable level	
Filters (Mono input)	HP	20-600Hz, 12dB/octave
	LP	1k-20Hz, 12dB/octave
EQ (Mono input)	HF	1k - 20kHz, +/-15dB, Q = 0.5 - 3.0 or shelf
	Hi-Mid	500 - 8kHz, +/-15dB, Q = 0.5 - 3.0
	Lo-Mid	70 - 1.5kHz, +/-15dB, Q = 0.5 - 3.0
	LF	30 - 480Hz, +/-15dB, Q = 0.5 - 3.0 or shelf
Metering	Overbridge: 12 VU Meters monitoring Group/Aux/Matrix & 3 VU Meters monitoring Left Mix/AFL/PFL, Right Mix/AFL/PFL & Mono (centre) mixes. Each meter has a peak LED set to 3dB below clipping level. Mono Input: 9-LED bargraph + Peak LED Stereo Input: 2 x 4-LED bargraph + Peak LED	
Power Consumption	48 Ch Console: each 17V rail draws 12.98A (nominal, without Littlites™) 8V rail draws 0.8 A (nominal)	
Weight	24Ch - 105 kg (231 lbs), 32Ch - 130 kg (286 lbs), 40Ch - 155 kg (341 lbs), 48Ch - 180 kg (396 lbs), 56Ch - 205 kg (451 lbs)	
Operating Conditions	Temperature range	-10°C to +30°C
	Relative humidity	0% to 80%
Power Supply Unit	Input voltage range: 230/200/115/100V AC +10%/-20% @ 50/60Hz Rated input power: 980 Watts Mains fuse rating: T10A/250V (slow-blow) Outputs: DC Voltage Rail Max Output Current +17V 16A -17V 16A +48V 0.5A +8V 1.25A Temperature Range: -10°C to +40°C Humidity: 0% to 90% (non-condensing ±5% relative humidity @40°C for 16 Hours, load switched between 20% and 100% at regular intervals) Dimensions: Height 177mm (4U) Width (chassis) 440mm Width (front panel) 482.6mm Depth (excl. handles) 436mm Weight: 30kg	



SOUNDCRAFT
HARMAN INTERNATIONAL INDUSTRIES LTD.
CRANBORNE HOUSE, CRANBORNE ROAD,
POTTERS BAR, HERTS, EN6 3JN, UK.
TEL: +44 (0)1707 665000
FAX: +44 (0)1707 660742
EMAIL: info@soundcraft.com
http://www.soundcraft.com

SOUNDCRAFT USA
1449 DONELSON PIKE,
NASHVILLE TN 37217, USA.
TEL: 1-615-360-0471
FAX: 1-615-360-0273
EMAIL: soundcraft-usa@harman.com

Part No. A4; ZL0435
US; ZL0436

Soundcraft reserve the right to improve or otherwise alter any information supplied in this document or any other documentation supplied hereafter. E&OE 02/01

This equipment complies with the EMC Directive 89/336/EEC



H A Harman International Company

Note: These figures are typical of performance in a normal electromagnetic environment. Performance may be degraded in severe conditions